

**GAS TURBINE ENGINE C3D-D-01**

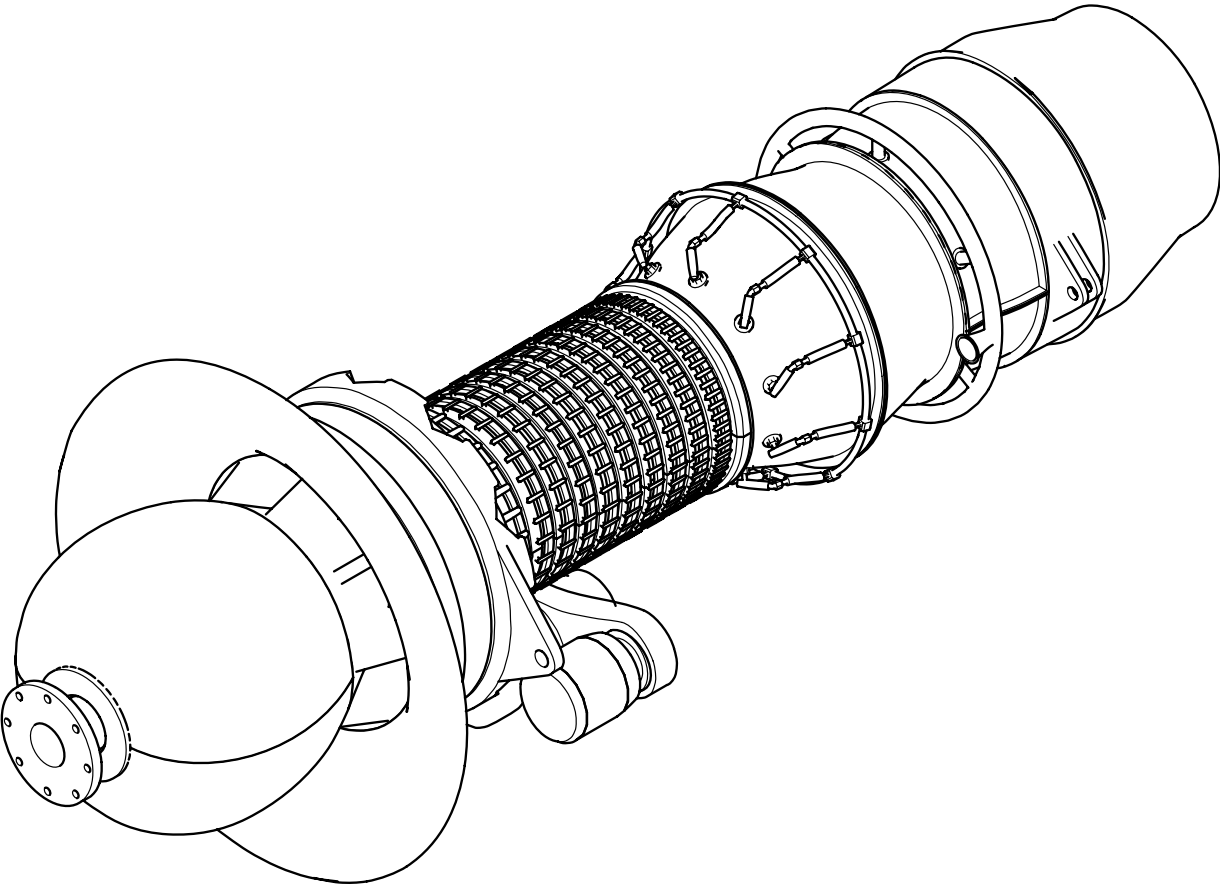

IMG\_000

GAS TURBINE ENGINE C3D-D-01

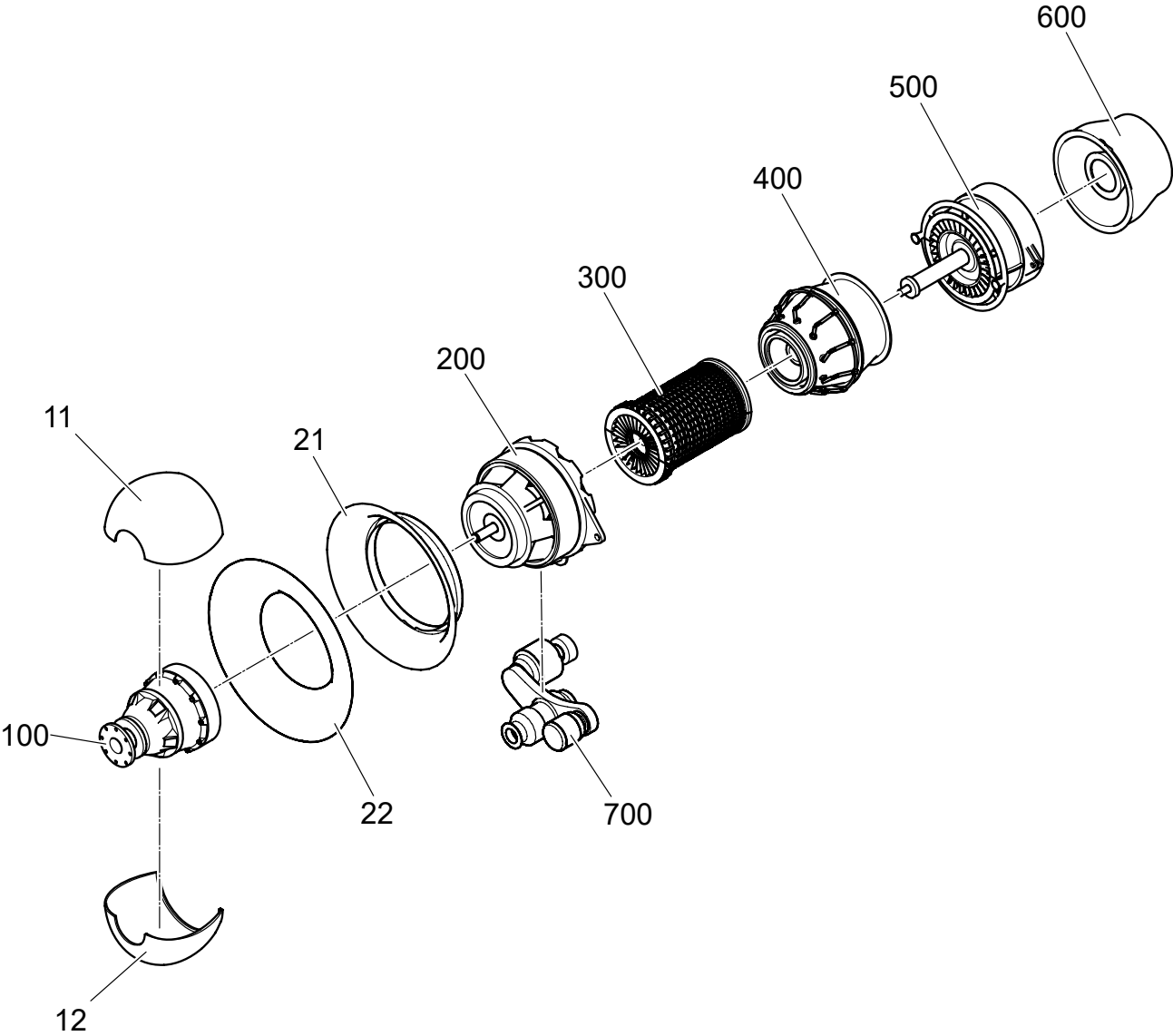

IMG\_001

GAS TURBINE ENGINE C3D-D-01

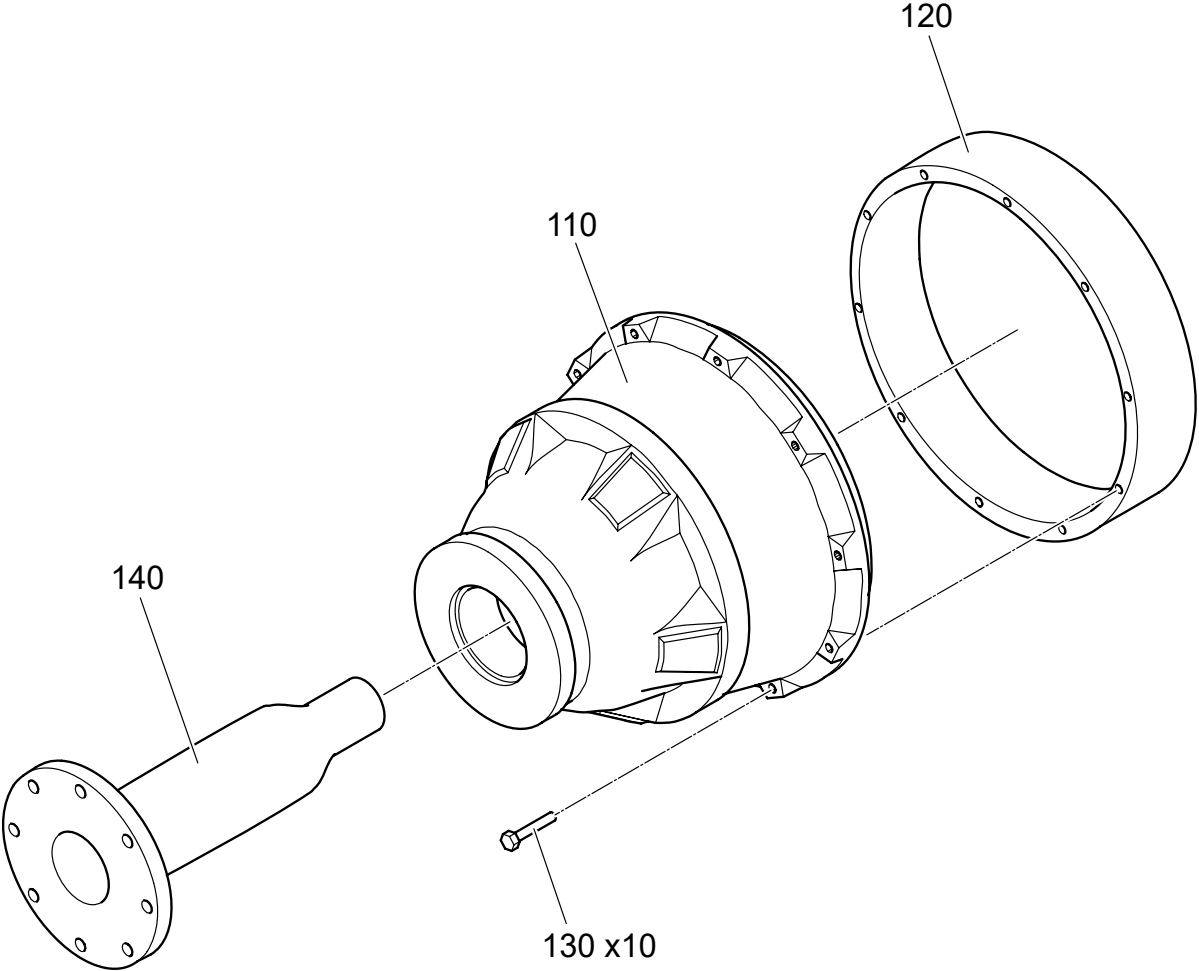

IMG\_002

**GAS TURBINE ENGINE C3D-D-01**

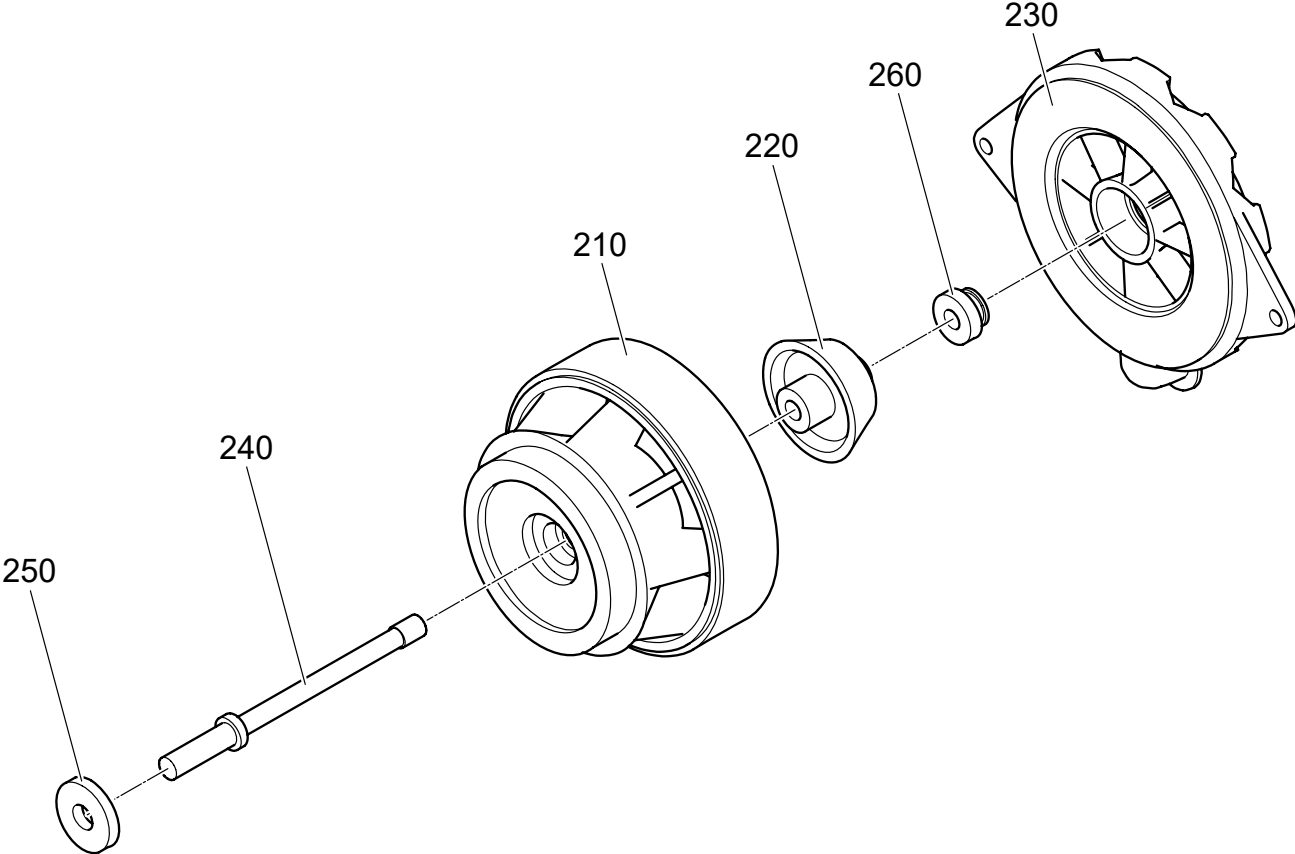

IMG\_003

GAS TURBINE ENGINE C3D-D-01

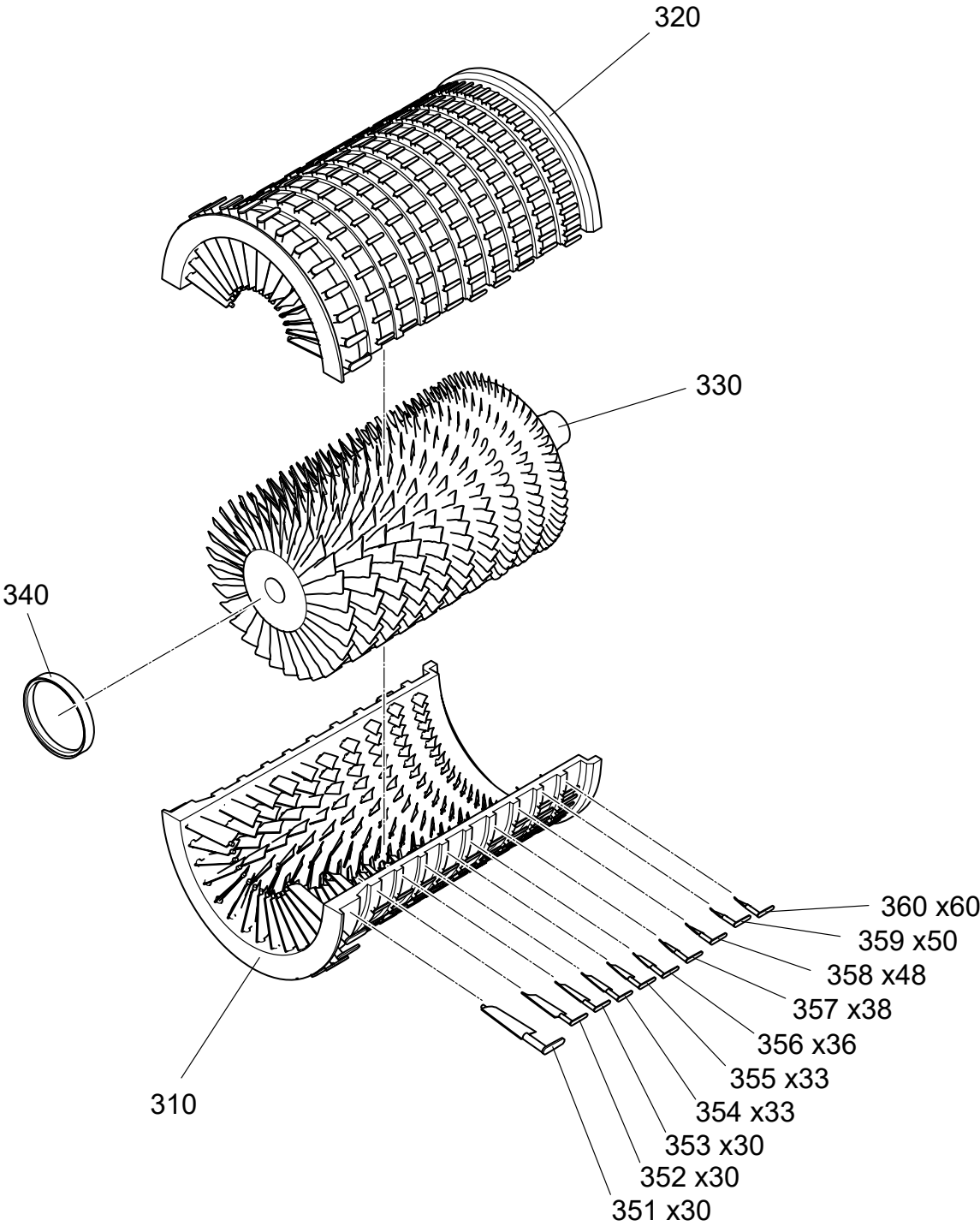

IMG\_004

GAS TURBINE ENGINE C3D-D-01

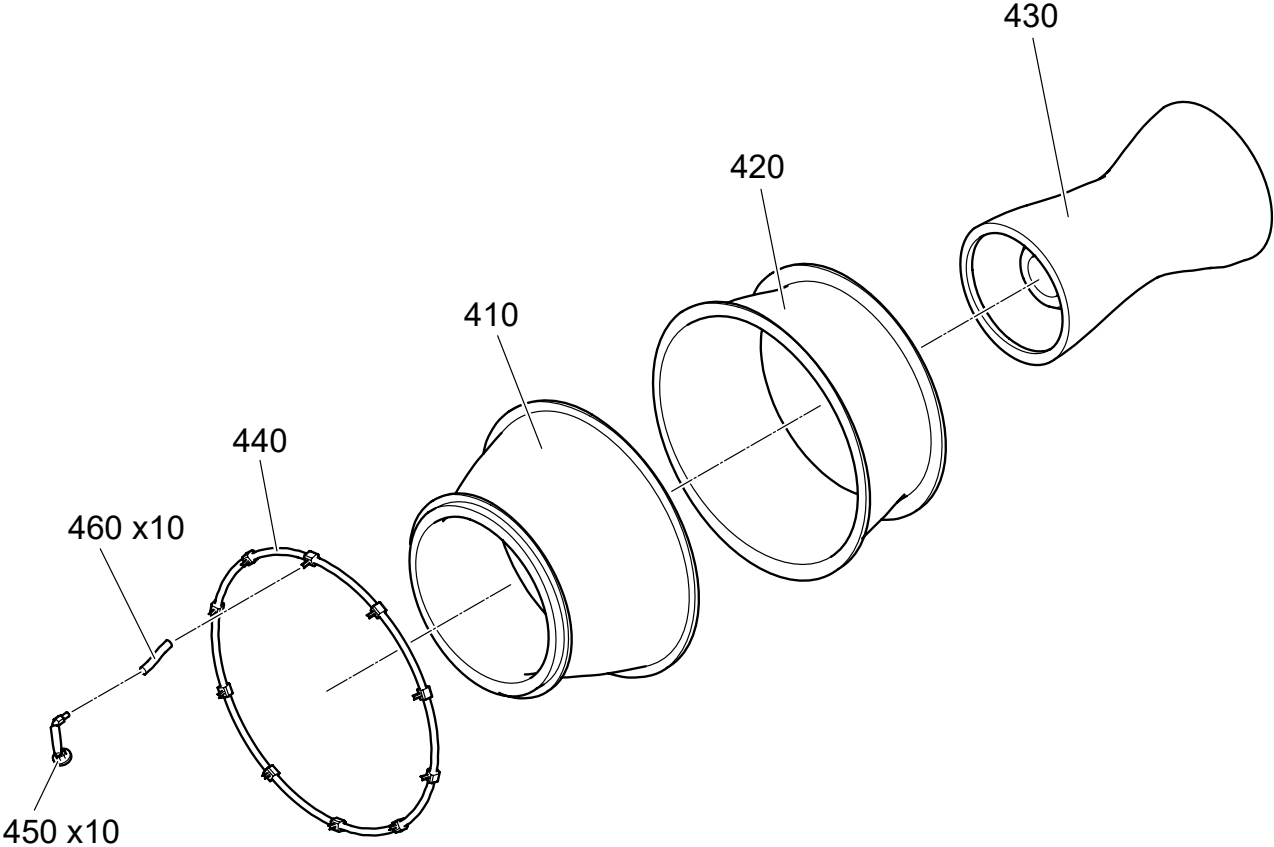

IMG\_005

GAS TURBINE ENGINE C3D-D-01

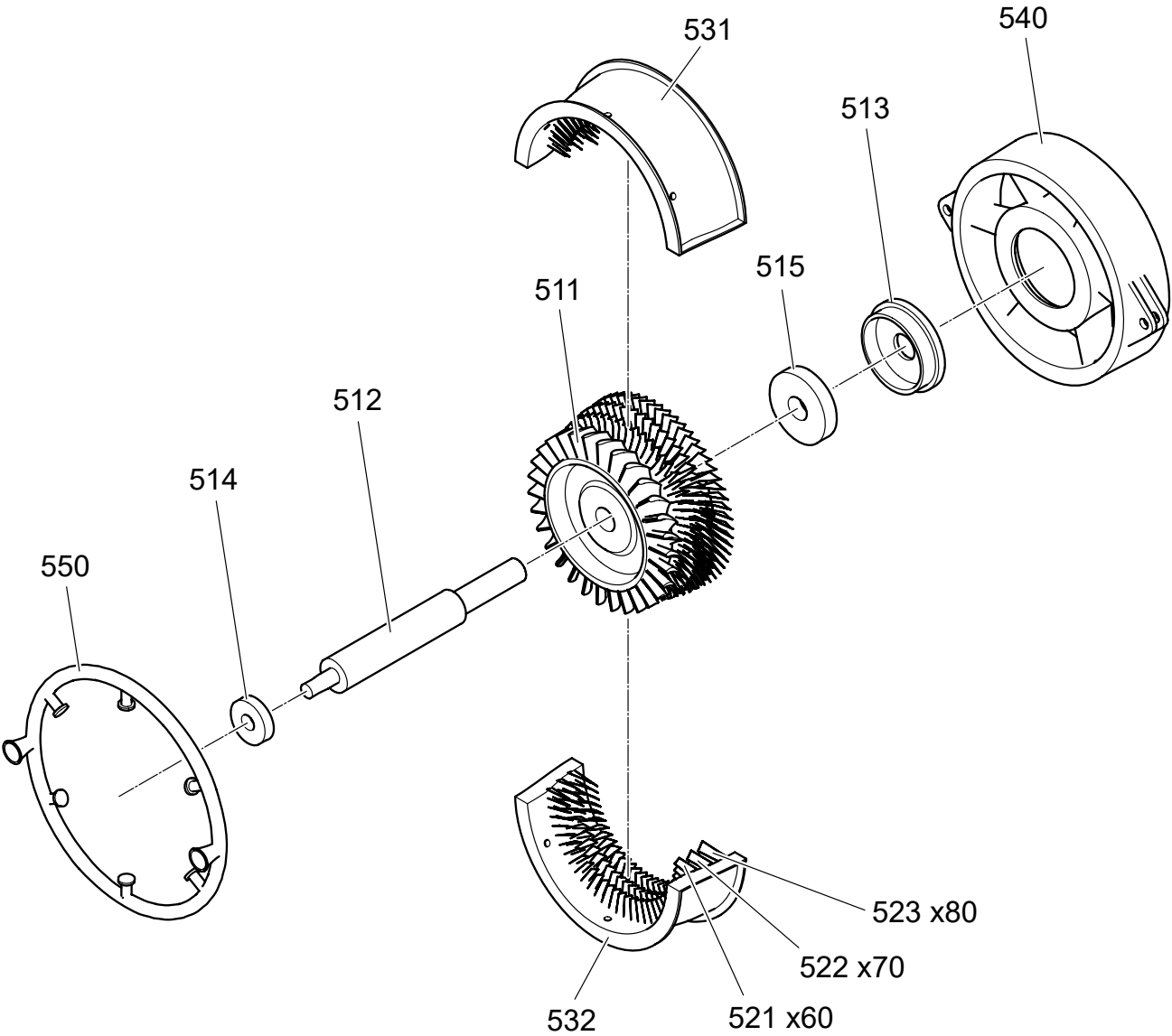

IMG\_006

**GAS TURBINE ENGINE C3D-D-01**

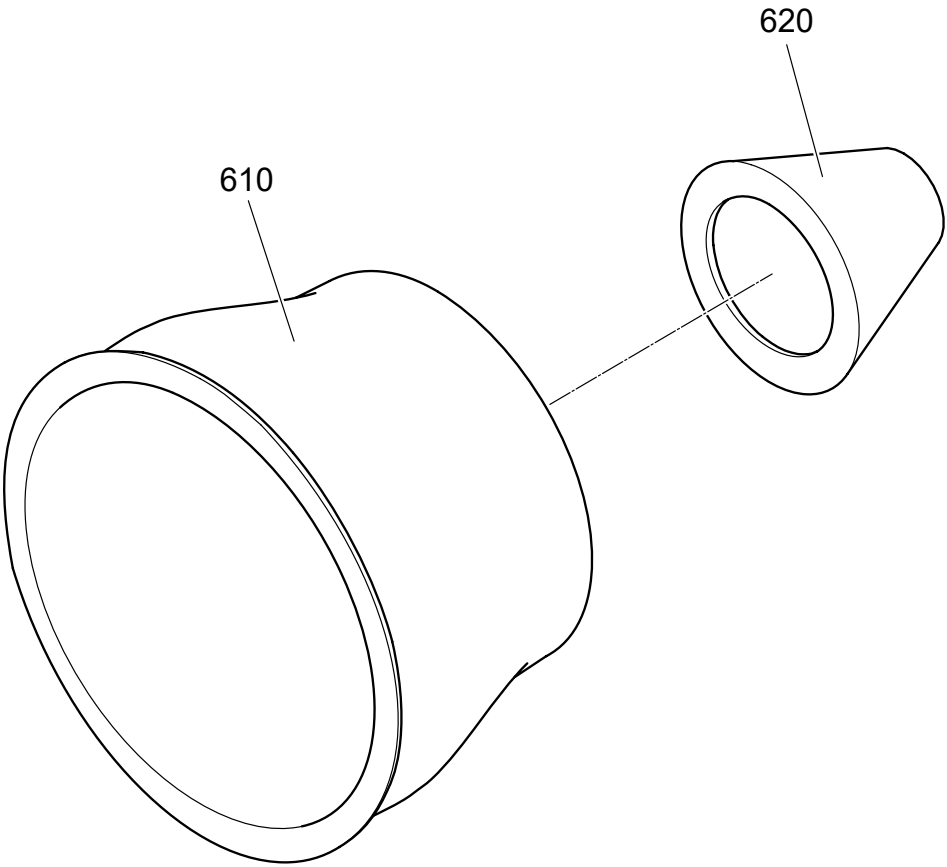

IMG\_007



GAS TURBINE ENGINE C3D-D-01

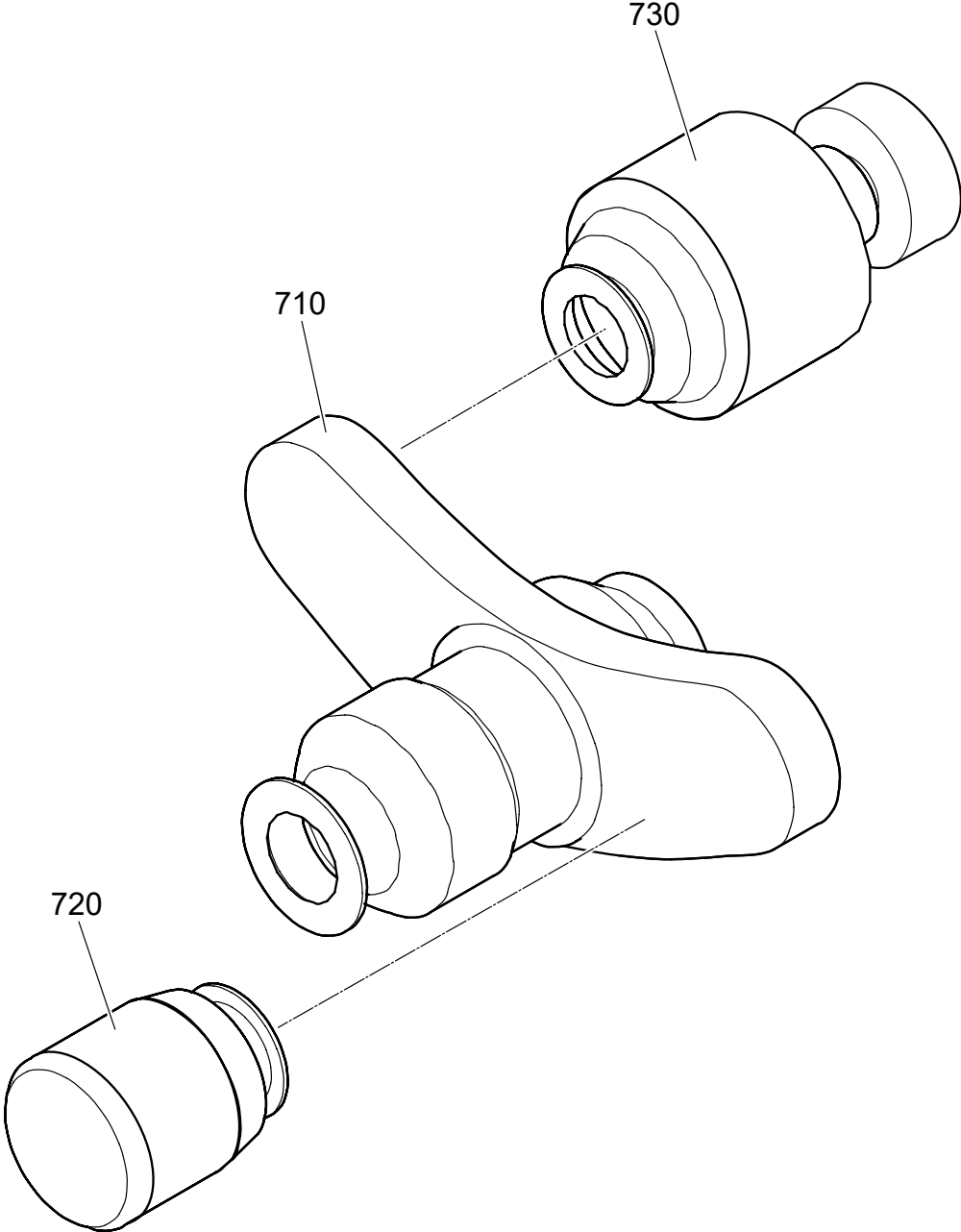

IMG\_008

## GAS TURBINE ENGINE C3D-D-01

ITEM	DESCRIPTION	PART NO.	QTY	INFO
1	GAS TURBINE ENGINE	C3D-D-01	1	
11	•REDUCTOR COVER - UPPER	RC-001	1	
12	•REDUCTOR COVER - LOWER	RC-002	1	
21	•INLET NOZZLE FRONT	IN-001	1	
22	•INLET NOZZLE REAR	IN-002	1	
100	•REDUCTOR MODULE	M-001	1	
110	••REDUCTOR ASSEMBLY	M-001-001	1	
120	••FRAME ADAPTER	M-001-002	1	
130	••BOLT	KOR-001	10	
140	••REDUCTOR SHAFT	M-001-001_215	1	
200	•FORWARD SUMP ASSEMBLY	M-002	1	
210	••FRONT FRAME	M-002-001	1	
220	••SUMP COVER REAR	M-002-002	1	
230	••SUMP COVER FRONT	M-002-003	1	
240	••DRIVE SHAFT	M-002-004	1	
250	••BEARING	B-001	1	
260	••BEARING	B-002	1	
300	•COMPRESSOR MODULE	M-003	1	
310	••COMPRESSOR LOWER CASE	M-003-001	1	
320	••COMPRESSOR UPPER CASE	M-003-002	1	
330	••COMPRESSOR ROTOR	M-003-003	1	
340	••CARRIER RING	M-003-005	1	
351	••STAGE 1 BLADE	M-003-000-001	30	
352	••STAGE 2 BLADE	M-003-000-002	30	
353	••STAGE 3 BLADE	M-003-000-003	30	
354	••STAGE 4 BLADE	M-003-000-004	33	
355	••STAGE 5 BLADE	M-003-000-005	33	
356	••STAGE 6 BLADE	M-003-000-006	36	
357	••STAGE 7 BLADE	M-003-000-007	38	
358	••STAGE 8 BLADE	M-003-000-008	42	
359	••STAGE 9 BLADE	M-003-000-009	50	

## GAS TURBINE ENGINE C3D-D-01

ITEM	DESCRIPTION	PART NO.	QTY	INFO
360	••STAGE 10 BLADE	M-003-000-010	60	
400	•COMBUSTION CHAMBER	M-004	1	
410	••FRONT HOUSING	M-004-001	1	
420	••REAR HOUSING	M-004-002	1	
430	••CRANKCASE	M-004-003	1	
440	••FUEL PIPELINE	M-004-004	1	
450	••FUEL NOZZLE	M-004-005	10	
460	••FUEL PIPELINE TO NOZZLE CONNECTOR	M-004-006	10	
500	•LOW PRESSURE TURBINE MODULE	M-005	1	
510	••TURBINE ROTOR	M-005-001	1	
511	•••ROTOR	M-005-005	1	
512	•••TURBINE SHAFT	M-005-007	1	
513	•••ROTOR COVER	M-005-006	1	
514	•••BEARING	B-003	1	
515	•••BEARING	B-004	1	
520	••TURBINE STATOR	M-005-002	1	
521	•••STAGE 1 BLADE	M-005-000-001	60	
522	•••STAGE 2 BLADE	M-005-000-002	70	
523	•••STAGE 3 BLADE	M-005-000-003	80	
531	•••LPT UPPER CASE	M-005-002-001	1	
532	•••LPT LOWER CASE	M-005-002-002	1	
540	••AFT FRAME	M-005-003	1	
550	••COOLING SYSTEM PIPELINE	T-001	1	
600	•OUTLET NOZZLE MODULE	M-006	1	
610	••OUTER NOZZLE	M-006-001	1	
620	••INNER NOZZLE	M-006-002	1	
700	•STARTER SYSTEM MODULE	M-007	1	
710	••STARTER SYSTEM GEARBOX	M-007-001	1	
720	••GENERATOR	M-007-002	1	
730	••STARTER	M-007-003	1	